

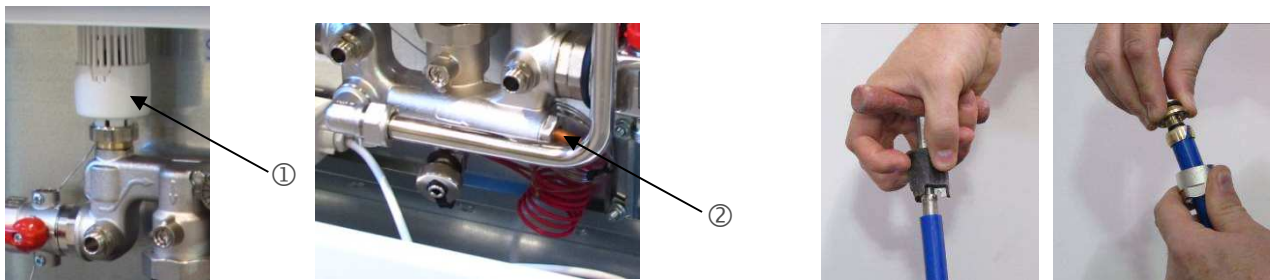

## Stainless steel manifold & mixing station

### Unpacking and initial assembly.

In order to protect fragile components, certain pieces are packed separately and need to be attached before proceeding. Firstly, the thermostatic valve ① linked to the copper probe ② needs to be attached as illustrated in the images below.



Ensure that the pipe is always de-burred before attaching Euro cone fittings using a bevelling tool. See above.

The three separately packed thermostatic dials should be inserted into the slots on the mixing valve casting (see positions on schematic diagram below).

It is recommended that all connections are tightened up before filling the manifold with water as they can become loose from transportation.

The surface mounted manifold cabinet should be fixed to the wall by simply drilling holes through the metal cabinet and fixing to the wall with screws.

Extra caution should be taken when installing flush mounted cabinets to ensure that the wall depth is compatible with the cabinet.

### Pre-installation - Plumbing information

Primary connections to the JUPITER manifold are made using standard 1" fittings. The manifold includes 1" ball valves. Primary pipe work for surface mounted cabinets should preferably be run to enter the manifold cabinet from beneath and left. Flush mounted cabinets come with punch out panels on the side so primary connections can enter from the left side or from beneath.

Systems with either large primary circuits or with three floors or more should be equipped with an automatic air vent device. The vents located on the manifold are intended for purging air from the JUPITER system and not the feed pipe work. The primary flow and returns should be back flushed and purged of air prior to the opening of the connected ball / isolating valves.

In order to protect the manifold pump from sludge and debris that is typically caused from the radiator system we recommend that a filter is installed on the feed into the manifold. We recommend the use of the MagnaClean Twin Tech system which filters both magnetic and non-magnetic particles.

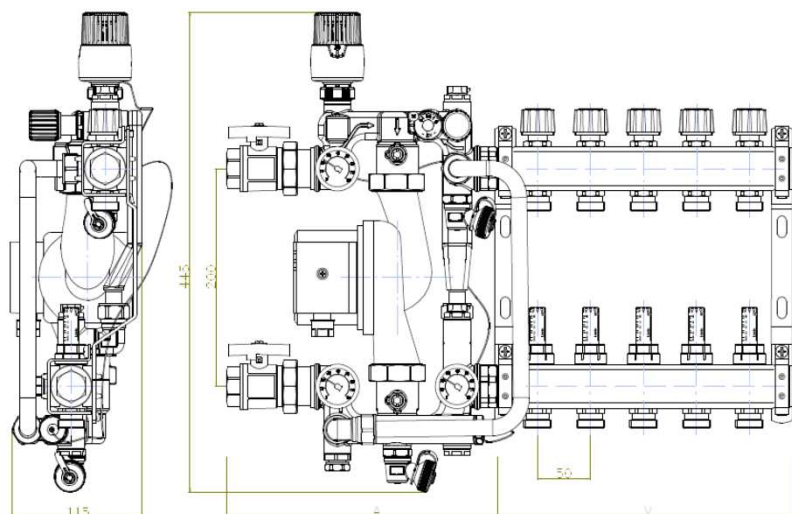



## Stainless steel manifold & mixing station

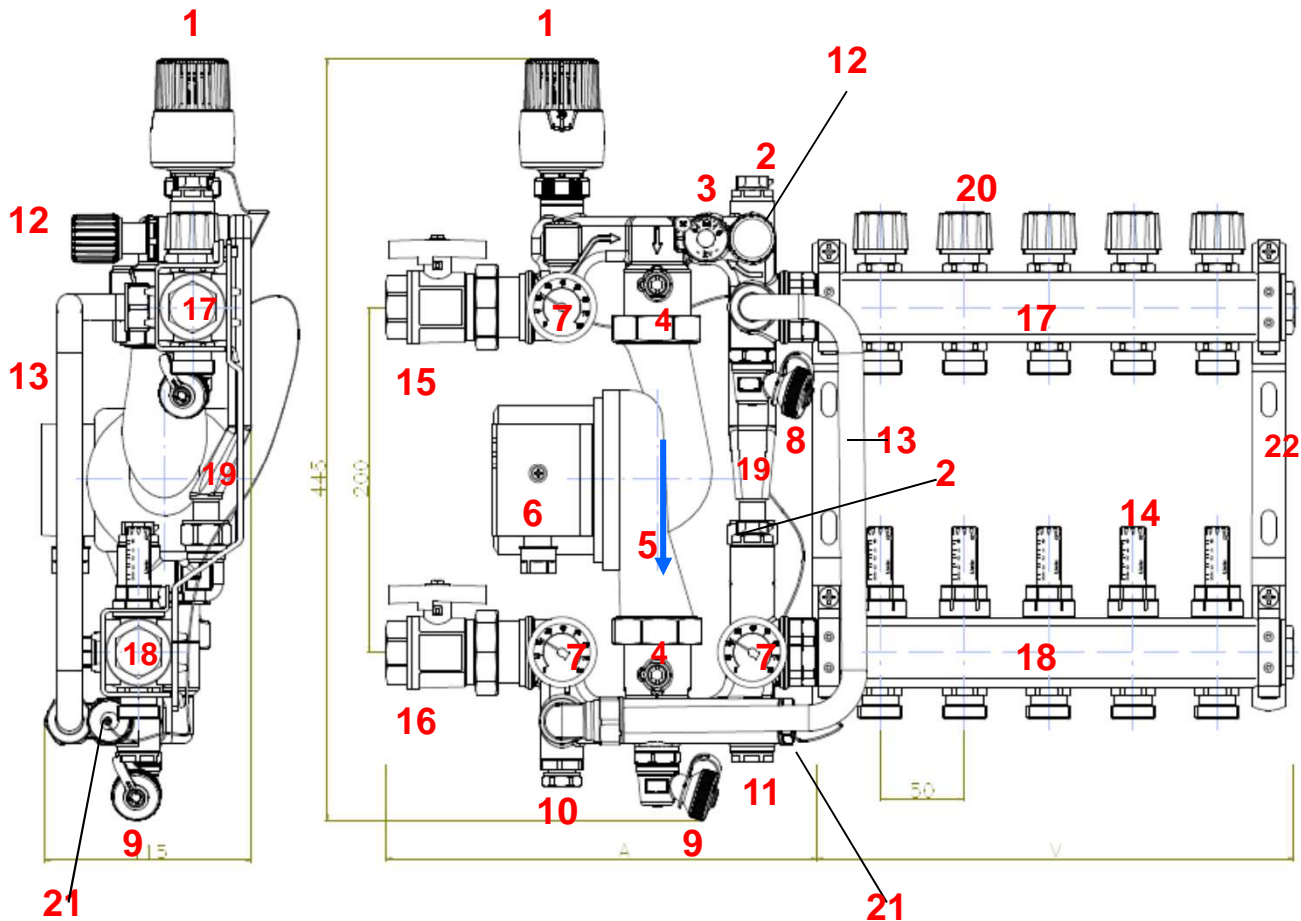

- |                                 |                                             |
|---------------------------------|---------------------------------------------|
| 1 Thermostatic regulating valve | 12 Adjustable differential pressure valve   |
| 2 Ventilation valves            | 13 Main return                              |
| 3 Balancing bypass regulator    | 14 Flow meters                              |
| 4 Internal ball valves          | 15 1" isolating valve (flow)                |
| 5 Flow direction from pump      | 16 1" isolating valve (return)              |
| 6 Pump                          | 17 Manifold (return)                        |
| 7 Thermometer x 3               | 18 Manifold (flow)                          |
| 8 Drain / fill valve            | 19 Bypass                                   |
| 9 Drain / fill valve            | 20 Heating circuit valve                    |
| 10 Return pipe isolating valve  | 21 Sensor for thermostatic regulating valve |
| 11 Thermostatic limiter         | 22 Wall brackets                            |

**TIP!** PLEASE ENSURE THAT THE RETURN PIPE VALVE (10) IS OPEN

# INSTALLATION GUIDE JUPITER



## Stainless steel manifold & mixing station



Close main flow and return isolating valves



Close upper and lower integral pump isolating valves

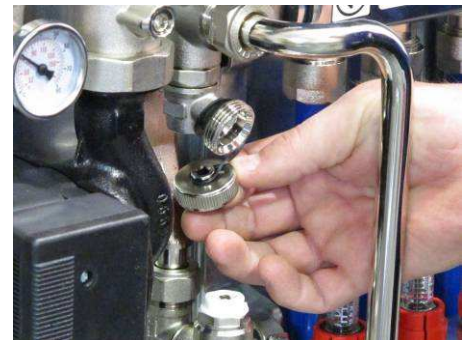

Open upper and lower fill & drain using the cap itself



Attach hose lock adapters to upper and lower valves



Take off red cap and fully open flow meters



Screw down all blue caps on top valves except for circuit you wish to fill



Fill via the lower valve and connect return hose to upper valve and allow to drain into an outside bucket.



Once no more air bubbles emerge, simultaneously close the completed circuit and open the next one.



Once purged with air close fill & drain valves using cap. Close upper return valve first then lower fill valve. Only then turn off water supply and remove hoses.



Re-open all blue caps on upper manifold prior to pressure testing. Connect pressure test equipment to upper return valve. Before connecting pressure test to the in-situ hose lock, pump some water out through the connecting pipe to avoid pumping more air into system. Before opening return valve with cap bring pressure up to approx. 5 bar.



Once connected pump up to 8 bar. Once satisfied that there are no leaks, leave on test for a minimum of 1 hour. Once completed decrease pressure to 2 bar and then close return valve using cap. Release remaining pressure before removing test equipment from manifold. Remove hose and close cap. Re-open integral ball valves above and below pump.



Do not adjust the primary water temperature regulator. The factory setting is 3. The unit is delivered with the black bypass knob closed. Once system is filled open by 1/16 of a turn anti clockwise. This allows water through the blending valve in the event that all circuits are closed.



## Stainless steel manifold & mixing station

### Other settings

As well the factory settings mentioned above the thermostatic dial should be set at approximately 40°C or 45°C unless otherwise stipulated. Flow temperature to the floor can be monitored using the thermostatic dial adjacent to the lower manifold although actual floor temperatures should be monitored using floor sensors if necessary.

### Over heating thermostat.

The over heat protection thermostat is located in the upper left hand corner of the manifold cabinet and should be set at approximately 5-10° above the thermostatic valve setting illustrated at the beginning of the document. Full instructions on changing the settings are delivered separately within the unit.

### Flow meters

Simply leave as delivered unless otherwise advised. The ideal flow rate is between 1.5 -2.4 l/m and can of course be adjusted if necessary.



Surface mounted



Flush fitting

### Manifold and manifold cabinet sizes

| Number of circuits                 | 2       | 3       | 4       | 5       | 6       | 7       | 8       | 9       | 10      | 11      | 12      |                |
|------------------------------------|---------|---------|---------|---------|---------|---------|---------|---------|---------|---------|---------|----------------|
| Manifold & mixing valve (width mm) | 450     | 500     | 550     | 600     | 650     | 700     | 750     | 800     | 850     | 900     | 950     |                |
| Cabinet sizes                      |         |         |         |         |         |         |         |         |         |         |         |                |
| Surface mounted (W)                | 530     | 680     | 680     | 680     | 830     | 830     | 830     | 1030    | 1030    | 1030    | 1030    | D:130mm        |
| Height (H)                         | 700     | 700     | 700     | 700     | 700     | 700     | 700     | 700     | 700     | 700     | 700     |                |
| Flush mounted (W)                  | 574     | 574     | 724     | 724     | 724     | 874     | 874     | 874     | 1024    | 1024    | 1024    | D:115mm (min.) |
| Height                             | 715-800 | 715-800 | 715-800 | 715-800 | 715-800 | 715-800 | 715-800 | 715-800 | 715-800 | 715-800 | 715-800 |                |