

Foam Glass Aggregate

JUPITER



CRK | (026) | Rev 1
July 2017

- Recycled waste glass
- Suitable for levels between 150mm – 900mm

Foam Glass Aggregate consists of millions of closed cells. The air locked within these cells give this remarkable aggregate outstanding insulation properties. The material is also completely frost proof and is anti-capillary which means that it cannot absorb any moisture therefore protecting the building fabric from mould and subsequent structural damage. Any water or moisture that does happen to pass through the aggregate can simply drain away.

Despite being lightweight at only 150 kg/m³ foam glass aggregate has a very high compressive strength of 275 kN/m².

Delivery form: Generally 1.5m³ bulk bags
 Density: ~150 kg/m³
 Aggregate size: 10-60mm
 Water absorption: 0.00

Compaction: Compacting should be performed with a lightweight vibrating shovel compactor. Excessive compaction, but does not have a negative impact on the performance. For design thickness greater than 300mm, placing and compaction should be undertaken in two or three separate layers.

Minimum compacted thickness: 150mm
 Maximum compacted single layer: 300mm

U – values (W/m ² K)	Loose thickness (mm)	Compacted thickness (mm)
0.80	130	100
0.53	195	150
0.40	260	200
0.32	325	250
0.27	390	300
0.18	585	450
0.11	975	750

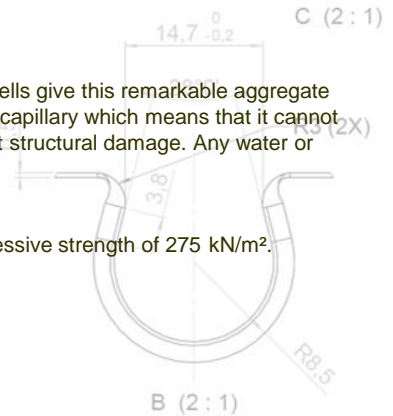

Foam glass aggregate size typically between 10-60mm



Foam glass can be gently compacted with a lightweight vibrating shovel compactor



Suitable for filling voids up to 900mm

JUPITER



JUPITER Heating Systems Limited
 The Barns, Pennypot Lane, Chobham, Surrey, GU24 8DJ
 T: 01276 859 066 www.jupiterunderfloorheating.com